



### Create Continua Certified Health Devices

- Single Chip platform for Continua Certified™ Health and Fitness devices, and device managers
- Low power *Bluetooth*® and USB design offers connectivity to a new class of portable health products
- Small footprint enables integration to existing products, as well as the creation of new compact device designs
- Demonstrated compatibility with Continua version one device connectivity standards
- Vena exploits the worlds leading *Bluetooth* solution to provide a compelling low cost point
- Vena reference design available, to develop your own Continua Certified™ products.
- Customisation services available

### Rapid route to a Continua Certified product

Cambridge Consultants has developed the first single chip implementation conforming to the Continua Health Alliance's Version One guidelines, and offers a reference design for the development of Continua Certified™ products.

### Complete platform for wireless health devices

The Vena platform embeds the IEEE Personal Health Data standard, along with *Bluetooth* Health Device Profile onto a single chip. Vena can be used to deliver a complete user interface including display driver. All that needs to be added is your chosen sensor.

The reference design includes development hardware, which can be used to rapidly prototype and test your product, as well as xIDE for Interface Express™ - a complete software development environment for high-performance 2.1/2.1+EDR *Bluetooth* applications development.

### New cost point

Through a complete single chip approach Vena brings a new cost point to connected health devices, with a module cost as low as \$10 in appropriate volumes.

### Compatibility by design

The Vena platform implements the full version one device connectivity standards defined by the Continua Health Alliance.



Continua  
HEALTH ALLIANCE

Vena is the first product to achieve Bluetooth Health Device Profile (HDP) Qualification<sup>1</sup>, providing reliable wireless connectivity.



In addition Vena can be configured to provide wired connectivity via the USB Personal Health Device Class.

Vena also includes the IEEE11073 personal health data framework, including a range of health device specialisations.

### Highly Integrated

By using *BlueCore*™, CSR's market leading *Bluetooth* solution, Cambridge Consultants' system minimises the PCB area required. This single chip solution is used to deliver both application and connectivity.

The Vena platform includes a full set of interfaces for a complete solution:

- 112x64 monochrome LCD
- LED drivers
- Keypad
- Storage

The platform includes power management for conventional or rechargeable Lithium Ion/Polymer batteries and a DC power supply. Enhanced charging performance can be achieved using an on board rapid charging unit.

[1. Bluetooth Qualified Design ID \(QD ID\) B014943](#)

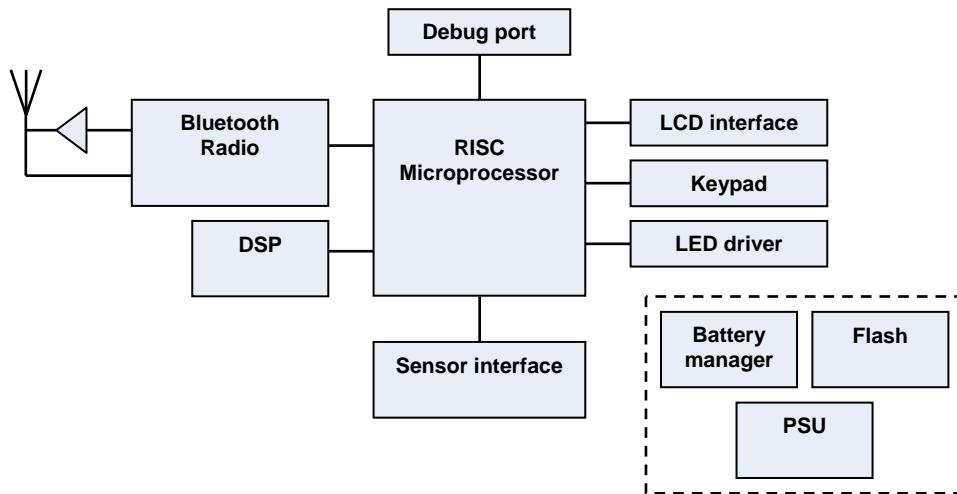

### Connected Health devices

The Vena platform contains all of the elements required to produce a complete device. For a medical device the platform can support a chosen sensor using the built in ADC. Alternatively connect to a wide range of OEM sensor modules using UART, SPI, or I<sup>2</sup>C.

### Complete device manager

The Vena platform can be used as the main processor for a device manager application, or can interface to a host processor for integration into an existing design. In both configurations Vena can simultaneously monitor multiple devices.

### Exceptionally low power

Cambridge Consultants exceptional radio system design capability has been applied to minimise the power requirements of the device. For periodic measurements this approach allows longer battery lifetimes and maximises product usability.

### Retrofit to existing devices

Vena can be used to provide connectivity to existing devices. It can be customised to work alongside your existing platform to provide the addition of a compatible communications interface.

### Future expansion

In addition to *Bluetooth* wireless technology the Vena platform offers software support for a range of other connections.

Standard wired connections can also be added via UART or USB.

The on-chip 24-bit DSP can be used for sensor input processing, additional security, or compression algorithms.

The user interface can also be modified to suit your application. Custom LCD displays can be accommodated from 8 bit colour 128 x 128, to low cost seven segment. Capacitive touch features and rotary encoders can be added to offer a richer product experience.

### Flexible engagement

The Vena platform is available to licence as a reference design, providing a complete development platform and tools.

Cambridge Consultants can also offer development services to rapidly integrate or modify the Vena platform to meet your needs, or to add connectivity to a new or existing product range.

Cambridge Consultants has a proven track record of delivering breakthrough products in the professional medical, and consumer markets. Our team of over 300 engineers and scientists deliver innovative solutions across a diverse range of industries including healthcare, consumer products, and wireless communication.

Bluetooth® is a registered trademark of Bluetooth SIG, Inc.

BlueCore™ is a trademark of CSR plc

© 2009 Cambridge Consultants Ltd and Cambridge Consultants Inc

Ref: CaseNote-WIRE-049 v3.1